

MODULE AR-334

SEQUENCER ASSEMBLY INSTRUCTIONS

It is recommended that you do the following before you proceed:

Find a place where you can work through completion, without disturbing your set-up.

Use adequate lighting

Wash your hands before starting. This removes contaminating oils and perspiration and makes assembly more comfortable.

As you proceed, check off each step with a pencil.

() 1. PREPARATION:

Lay the circuit board down on a sheet of white paper. PLACE METAL FOIL SIDE DOWN! Turn board so that connector strip is to the left.

Lay the assembly drawing near the board.

Unpack the parts carefully and place in a large box or tray so they won't get lost.

HAVE THE FOLLOWING TOOLS NEARBY:

Pencil tip soldering iron, hot and tinned (solder coated)

Solder; USE ONLY THIN ROSIN-CORE SOLDER!

Small, diagonal wire cutters

Small wire strippers

Small long-nose pliers

Flat blade screw driver

1/2" or #16 nut driver

5/16" or #10 nut driver

1/4" or #3 nut driver

A pair of regular pliers can substitute for the nut drivers but will not be as easy to use.

() 2. RESISTORS:

Carefully install all 84 resistors on the circuit board. See general assembly instructions. Double check your installation against the P.C. board component layout drawing to be sure that the correct value is in the correct location. To prepare the resistor for insertion, hold the body of the resistor between the thumb and index finger of your left hand. With the thumb and index finger of your right hand bend both leads of the resistor at once to form right angles with the body. The resistor will now insert easily into the P.C. board. Once the resistor is inserted, bend the leads on the foil side to hold the resistor in place. Solder the resistors to the board and cut the leads about 1/16 of an inch away from the board.

For ease in reading the resistor values on the P.C. board install the resistors with the gold band facing either the bottom or the right-hand side of the board.

- a) Install the sixteen 330K resistors; R70 - 77 & R58 - 65; solder & cut leads
- b) Install the remaining 330K resistors; R53,48,43,38,33,28,23,18; solder & cut leads
- c) Install the eight 10K resistors; R55,50,45,40,35,30,25,20; solder & cut leads
- d) Install the eleven 1K resistors; R54,49,44,39,34,29,24,19,69,81,57; solder & cut leads
- e) Install the eight 470K resistors; R56,51,46,41,36,31,26,21; solder & cut leads
- f) Install the four 39K resistors; R3,6,14,13; solder & cut leads
- g) Install the four 47K resistors; R1,4,11,6; solder & cut leads
- h) Install the two 220K resistors; R78 & 66; solder & cut leads
- i) Install the one 150K resistor; R-7; solder & cut leads
- j) Install the one 5.6K resistor; R-15; solder & cut leads
- k) Install the twenty-one 100K resistors; R52,47,42,37,32,27,22,17,2,5,12,84,83,82,8,9
10,79,80,67,68, solder & cut leads

- () 3. DIODES:
Install diodes CR1 and CR2 on the circuit board. Double check the polarity of the diodes. Solder and cut leads.
- () 4. INTEGRATED CIRCUITS
At this time install only the two 1458 dual operational amplifiers (A1 & A2). IC 1 & IC 2 are CMOS integrated circuits and are subject to damage from static charges. Do not remove these ICs from their protective conductive foam until all the module assembly steps have been completed. Double check your installation and solder the leads.
- () 5. TRANSISTORS
Install all 20 transistors on the circuit board. (Q1 through Q20). Check the P.C. board component layout for correct orientation of the transistor leads. Solder and cut the leads.
- () 6. CAPACITORS
Install capacitors C1 through C9 on the circuit board. Observe polarity. If there is no polarity marking the capacitors may be installed in either direction. Double check your installation. Solder and cut the leads.
- () 7. WIRE SADDLE
Snap the wire saddle into the hole on the P.C. board as shown on the component layout.
STILL DO NOT INSTALL THE CMOS ICs AT THIS TIME
Set the circuit board aside and go on to the front panel wiring instructions.

FRONT PANEL ASSEMBLY PROCEDURE

Due to the size and number of the components on the face panel and to the unusually large number of wires required for this module, we have changed the normal wiring procedure. Rather than mounting all the parts and wiring them, the AR-334 requires that some parts be mounted then wired, then other parts mounted and wired and so on. We suggest that you use the color coded wire for these functions

BROWN: CW TAP P1, CATHODE L1, TIP JACK G1
 ORANGE: " " P2, " L2, " " G2, TIP JACK A
 YELLOW: " " P3, " L3, " " G3, CENTER TAP (A) OF ALL 8 INNER POTS
 GREEN: " " P4, " L4, " " G4, TIP JACK B
 BLUE: " " P5, " L5, " " G5
 VIOLET: " " P6, " L6, " " G6
 GREY: " " P7, " L7, " " G7, TIP JACKS RESET, CLOCK, RUN ENABLE & STEP;
 SHUNT JACK RUN ENABLE & STEP; STEP & RUN
 TERMINALS OF SWITCH
 WHITE: CW TAP P8, CATHODE L8, TIP JACK G8, CENTER TAP (B) OF ALL 8 INNER POTS
 RED: +15v TERMINAL OF SWITCH, LD FROM LEDS
 BLACK: GROUND OF JACKS

Refer to the panel wiring diagram.

- () 1. Install all 13 mini-phone jacks as shown on the front panel drawing.
- () 2. Solder a wire to the grounds of all 13 jacks as shown in the panel wiring diagram. Solder a wire from the ground pins of the Reset and Clock jacks to their respective shunt pins as shown on the wiring diagram. This wire does not have to be insulated.
- () 3. Cut and strip 15, 14" long pieces of insulated wire. Solder one end of each wire to the tip of each jack. Solder one end of 14" long wire to the shunt of the Run Enable & Step jack. Solder one end of a wire to the ground of the R, E & S jack.
- () 4. Install the switch S1 on the front panel as shown in the wiring diagram. Be sure

that the momentary action of the switch is toward the Step position.

- () 5. Solder three one foot long pieces of wire to the three terminals of the switch.
- () 6. Now install all eight light emitting diodes. Insert the longer of the two pieces of LED mounting hardware through the front panel so that the washer-like surface rests on the front panel and the cylindrical part extends through and protrudes from the back surface of the front panel. Insert the LED from the back into the cylindrical section so that the rounded end sticks out through the section of washer on the front surface of the panel. Rotate the LED so that the Anode lead is to the left. The anode lead will be the longer and thinner of the two leads. Insert the second piece of mounting hardware over the leads of the LED and the cylindrical section of the first piece. Push the second piece all the way up to the panel so that the two pieces of mounting hardware are clasping the panel and holding the LED firmly in place.
- () 7. Run an insulated wire connecting the anodes of all eight LEDs as shown on the panel wiring diagram. Connect a 12" piece of wire to the anode of LED 4 as shown. These wires should be soldered as close to the body of the LED as practical. Cut the anode lead after the wires have been soldered.
- () 8. Cut and strip eight 14" pieces of wire. Solder one each to the cathode of each LED as shown in the wiring diagram. These wires should be soldered as close to the body of the LED as practical. Cut the cathode lead after the wires have been soldered. With a piece of tape, label the wire from each LED as LED-1, LED-2, etc.
- () 9. Install the four pots P5 through P8 on the front panel. On pots 6, 7, & 8, insert the spacer nut between the body of the pot and the lock washer before installing the pot on the panel. Install all four pots with their pins oriented as shown on the panel wiring diagram. Do not overly tighten pot 5. It will have to be removed later in order to install the frame.
- () 10. Connect an insulated jumper wire between the two clockwise CW terminals of each pot. Do not solder.
- () 11. Connect a 14" long piece of wire to the top, CW terminals of each pot. Solder the CW terminals of the pots. Bundle these together using a piece of tape, wire or ty-wrap.
- () 12. Connect an insulated jumper wire between the counter clockwise CCW terminals of each pot; do not solder.
- () 13. Following the wiring diagram, connect a 2" long piece of insulated wire between the CCW terminals of pot 5 and pot 6. Connect a jumper wire between the CCW terminals of pot 6 and pot 7 and between pot 7 and pot 8. Connect an insulated wire between the CCW terminal of pot 8 and the ground pin of the Run Enable & Step jack. Solder all connections.
- () 14. Solder one end of the 14" piece of wire to the center tap of all four dual pots. Group the four B wires together and label with a piece of tape. Group the four A wires together and label with a piece of tape. It is not important that you separate the wires B1 from B2, etc., or A1 from A2, etc. These wires are returned to the summing node of each channel.
- () 15. Now that pots 5 through 8 are installed and wired, install and wire pots 1 through 4. Repeat steps 9 through 14 for the installation of pots 1 through 4.

- () 16. When all the pots are wired remove pots 1 and 5 from the panel (in preparation for the module assembly) and set the panel aside.

AR-334 MODULE ASSEMBLY INSTRUCTIONS

Please refer to Module Assembly drawing.

- () 1. Unpack the frame, bag of hardware and front panel.
- () 2. Snap the two plastic card guides into the holes in the frame. Be sure that the pairs of tabs point toward the rear, as shown.
- () 3. Slide the printed circuit board into the frame, holding top and bottom of frame together against the board, so that the board fits snugly in the guides, between the tabs.
- () 4. Using the 4-40 x 3/8" screws and nuts, mount the two angle brackets to the frame, as shown. The brackets should be on the component side of the board.
- () 5. Now screw the board to the brackets. Insert the 4-40 x 3/8" screw from foil side of board. **DOUBLE CHECK THAT SCREW HEAD DOES NOT TOUCH ANY METAL FOIL!!!**
- () 6. Refer again to MODULE ASSEMBLY drawing. Mount top of panel to frame, using the two UPPER pots (P1 and P5). Put on lock-washers and insert pot shaft through rear of upper holes in front of frame. Bring panel against frame, so these pots also go through matching holes in panel. Tighten nuts on front of panel, with pots oriented in same direction as lower pots.
- () 7. Attach bottom of panel to frame, using remaining 4-40 x 3/8" screws and nuts.
- () 8. Turn all pot shafts fully counterclockwise, and mount the knobs pointing to the leftmost number. Tighten knob screws.

THIS COMPLETES MODULE ASSEMBLY, EXCEPT FOR FINAL PANEL WIRING

Panel wiring---refer to PANEL WIRING diagram and P.C. LAYOUT drawing:

- () 9. Wire each wire from the front panel to the P.C. board. Connect one wire at a time. Run the wire through the wire saddle to the point on the board where it is to be soldered. Cut the wire one inch longer than necessary to allow for some slack. Connect the wires in this order:
 - a) Tips of jack G1 - G8 to G1 - G8 on board
 - b) Tips of jack Reset to Reset on board
 - c) Tips of jack Clock to Clock on board
 - d) Tips of jacks A-out and B-out to A-out & B-out on board
 - e) Ground of jacks Run Enable & Step to M on board
 - f) Shunt of jacks Run Enable & Step to Shunt
 - g) Tip of jack Run Enable & Step to Run, enable & step
 - h) Wires from switch to STEP, +15v & RUN respectively
 - i) LEDs 1 - 8 to 1L - 8L on board
 - j) CW taps of pot 1 - 8 to 1P - 8P on board

Connect all eight A wires on the pots to the AP IN terminals on the P.C. Board.
It does not matter which wires go to which pad.
Connect all eight B wires on the pots to the BP IN terminals on the P.C. Board.
It does not matter which wires go to which pad.
The panel wiring is now complete.

- () 10. Now install IC-1 and IC-2 on the P.C. board and solder in place.
YOUR AR-334 SEQUENCER IS NOW COMPLETELY ASSEMBLED AND READY TO USE.

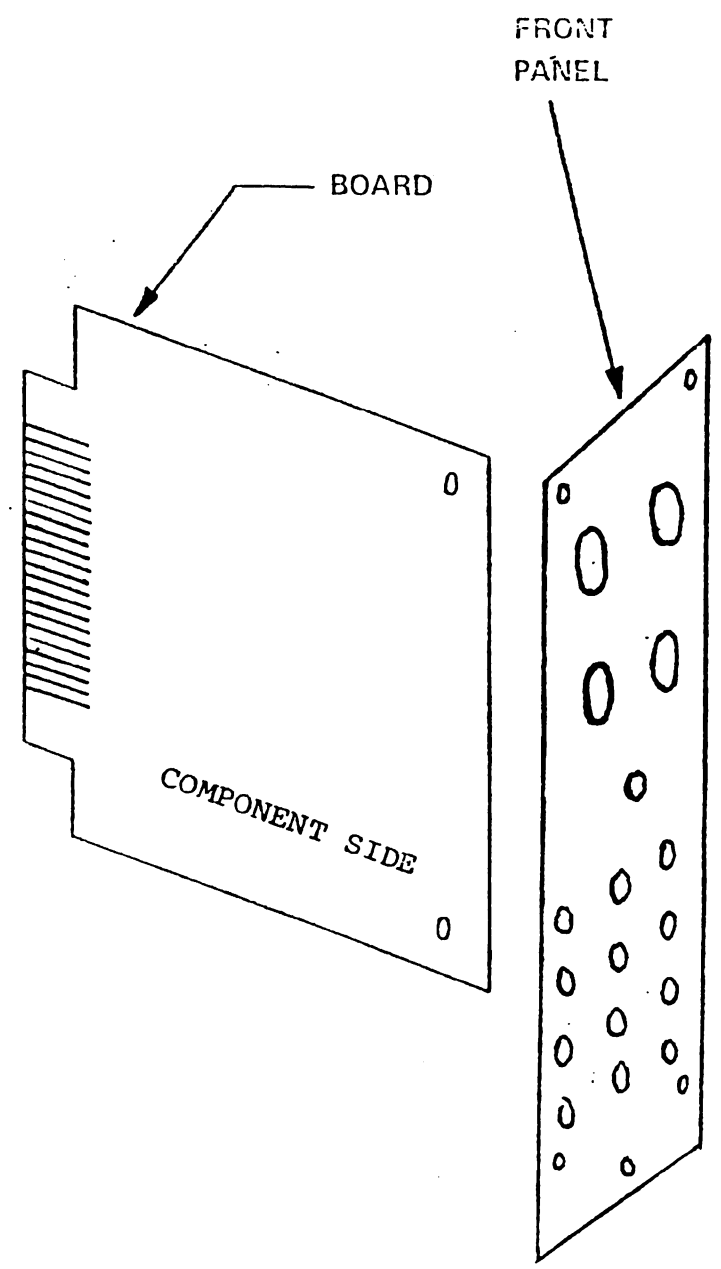
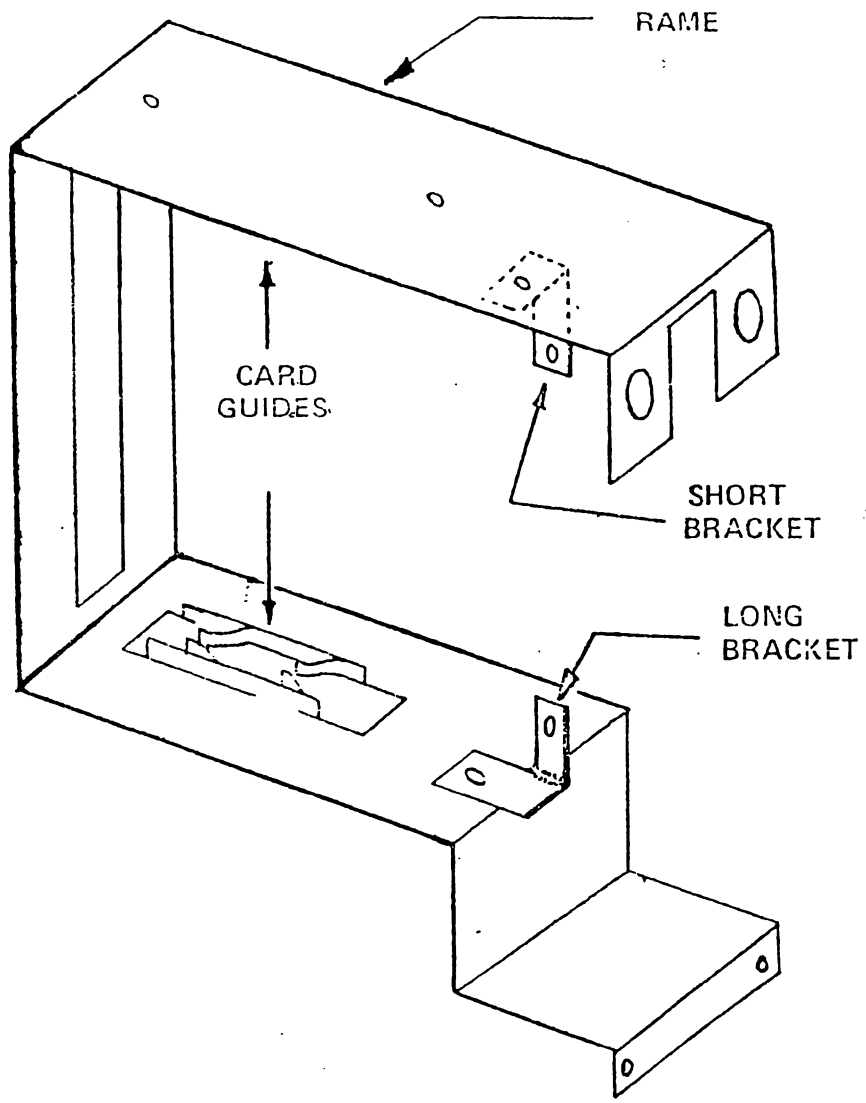

AR334 SEQUENCER
FRONT PANEL WIRING DIAGRAM

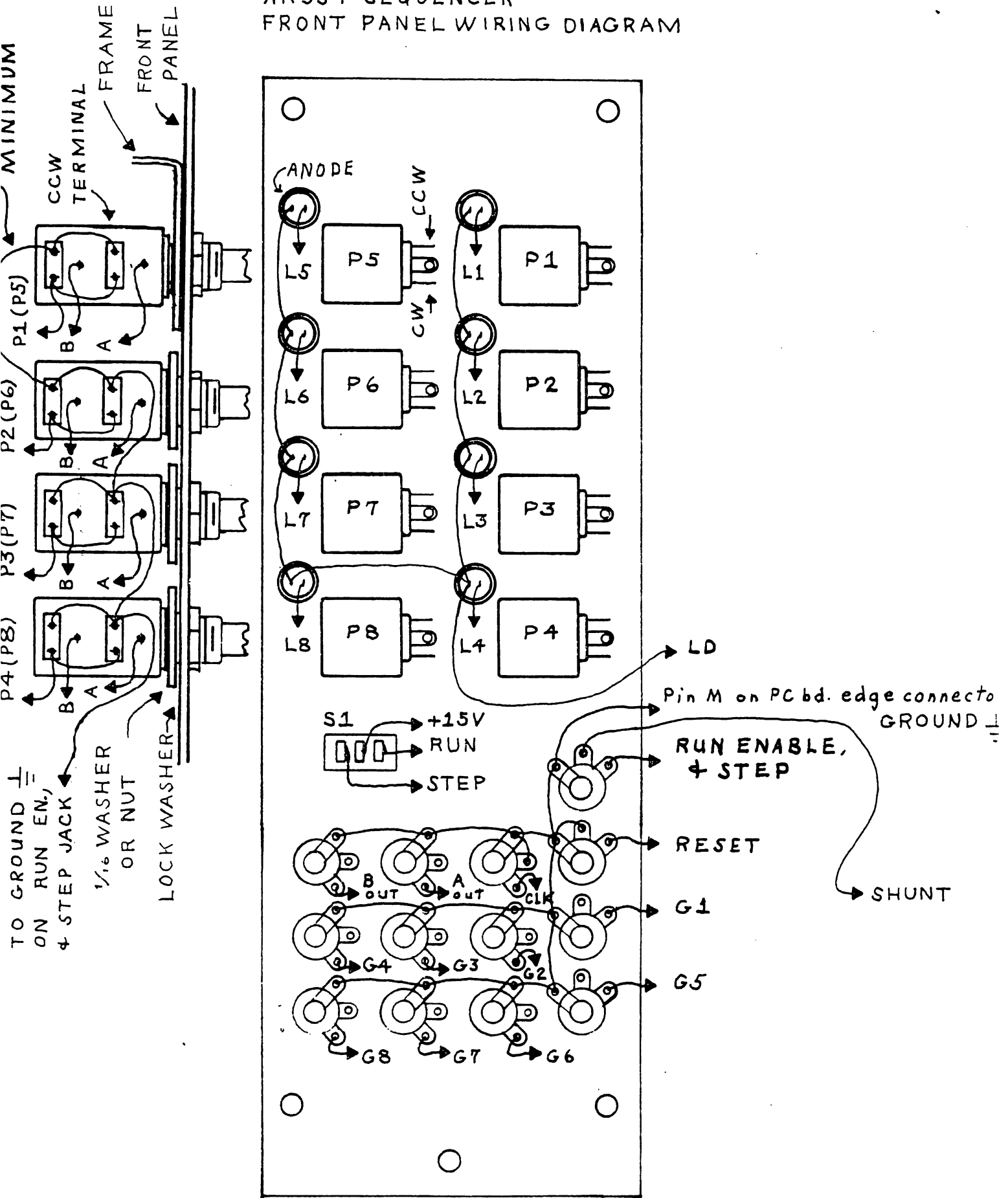

AR-334 SEQUENCER

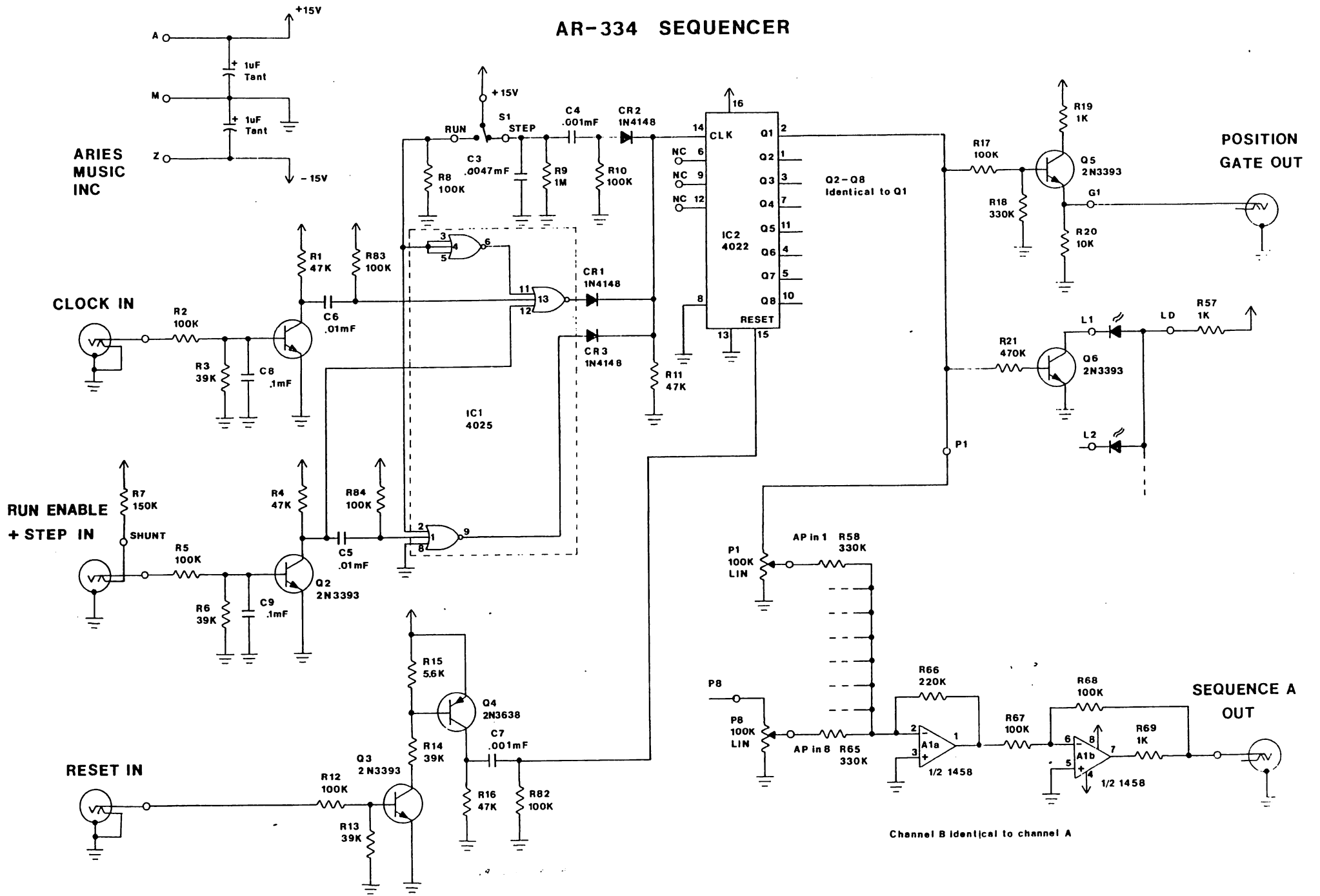

AR-334 SEQUENCER Parts

PARTS LIST * AR-334 * SEQUENCER

QUANTITY	DESCRIPTION	VALUE
	RESISTORS:	
11	1/2w carbon film 5% tolerance	1K ✓
1	" " " " "	5.6K ✓
8	" " " " "	10K ✓
4	" " " " "	39K ✓
4	" " " " "	47K ✓
21	" " " " "	100K ✓
1	" " " " "	150K ✓
2	" " " " "	220K ✓
24	" " " " "	330K ✓
8	" " " " "	470K ✓
8	Dual Concentric Potentiometers	100K linear
2	Tantalum Capacitor	1 uf ✓
2	Disc Capacitor	.001 uf ✓
2	" "	.01 uf ✓
2	" "	.1 uf ✓
1	" "	.0047 uf ✓
3	Diodes	1N4148 ✓
19	Transistor (NPN)	A3393 or 2N3393 ✓
1	" (PNP)	2N3638 ✓
2	Intergrated Circuit (dual OpAmp)	1458 ✓
1	" " (CMOS)	4025 ✓
1	" " "	4022 ✓
1	Toggle Switch	on - off - on momentary
13	Mini Jacks	
8	LEDs	
8 sets	LED Mounting Hardware	
1	Wire Saddle	
6	3/8" diameter nut	
8 sets	Dual Concentric Knobs	100k lin./100K lin.
1	AR-334 Front Panel	
1	AR-334 P.C. Board	
1	Module Frame	
1	Bracket	large
1	Bracket	small
6	Screws	#4-40 x 3/8"
6	Nuts	#4-40
2	P.C. Card Guides	
1	Black 14" Length wire	
4	Brown " " "	
2	Red " " "	
5	Orange " " "	
12	Yellow " " "	
5	Green " " "	
4	Blue " " "	
4	Violet " " "	
10	Grey " " "	
12	White " " "	
24	AWG gauge copper tinned bus wire	60"